

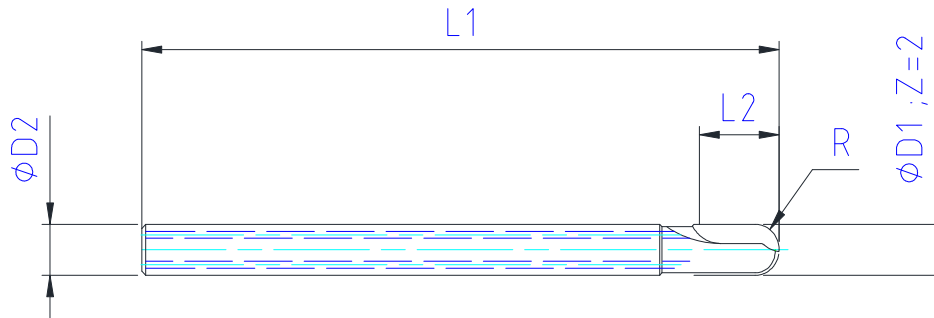

**Simply The Precision.**

### AA - B



- Application:**
- aluminium machining
  - GFK/CFK machining
  - graphit machining

Type of coolant (with/without) and lead angle upon customer request.

Product Number	$\phi D1$	$\phi D2$	L1	L2	Z	R
AA-B.3351	3.0	3	60	5	1	1.5
AA-B.44101	4.0	4	60	10	1	2
AA-B.66102	6.0	6	80	10	2	3
AA-B.88102	8.0	8	80	10	2	4
AA-B.1010102	10.0	10	80	10	2	5
AA-B.1212102	12.0	12	100	10	2	6
AA-B.1616103	16.0	16	130	10	3	8
AA-B.2020133	20.0	20	160	13	3	10

### AA - M

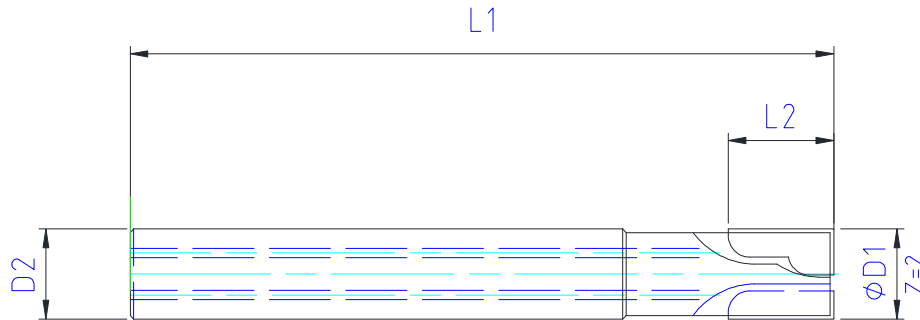

- Application:**
- aluminium machining
  - GFK/CFK machining
  - graphit machining

Type of coolant (with/without) and lead angle upon customer request.

Product Number	Ø D1	Ø D2	L1	L2	Z
AA-M.66102	6.0	6	60	10	2
AA-M.66152	6.0	6	60	15	2
AA-M.66202	6.0	6	80	20	2
AA-M.88102	8.0	8	80	10	2
AA-M.88152	8.0	8	80	15	2
AA-M.88202	8.0	8	80	20	2
AA-M.1010102	10.0	10	80	10	2
AA-M.1010152	10.0	10	80	15	2
AA-M.1010202	10.0	10	80	20	2
AA-M.1212102	12.0	12	100	10	2
AA-M.1212152	12.0	12	100	15	2
AA-M.1212202	12.0	12	100	20	2

### AA - S

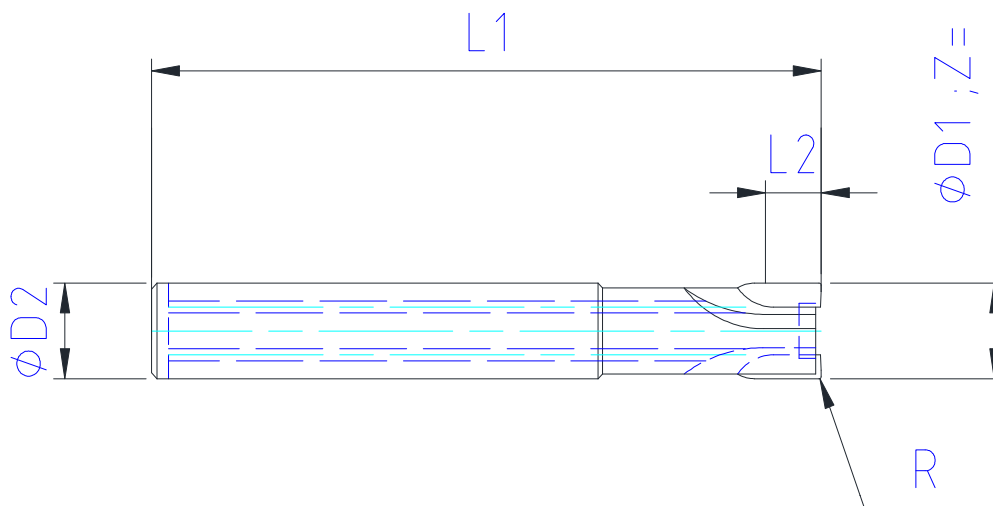

- Application:**
- aluminium machining
  - GFK/CFK machining
  - graphit machining

Type of coolant (with/without) and lead angle upon customer request.

Product Number	$\phi D1$	$\phi D2$	L1	L2	Z
AA-S.6852	6.0	8	55	5	2
AA-S.8852	8.0	8	60	5	2
AA-S.101052	10.0	10	75	5	2
AA-S.1212103	12.0	12	85	10	3
AA-S.1416103	14.0	16	85	10	3
AA-S.1616103	16.0	16	85	10	3
AA-S.2020103	20.0	20	100	10	3

# AA DIAMONDS

PRECISION CUTTING TOOLS



Based in Prague, covering whole Europe.